

SPNII Actuator Information

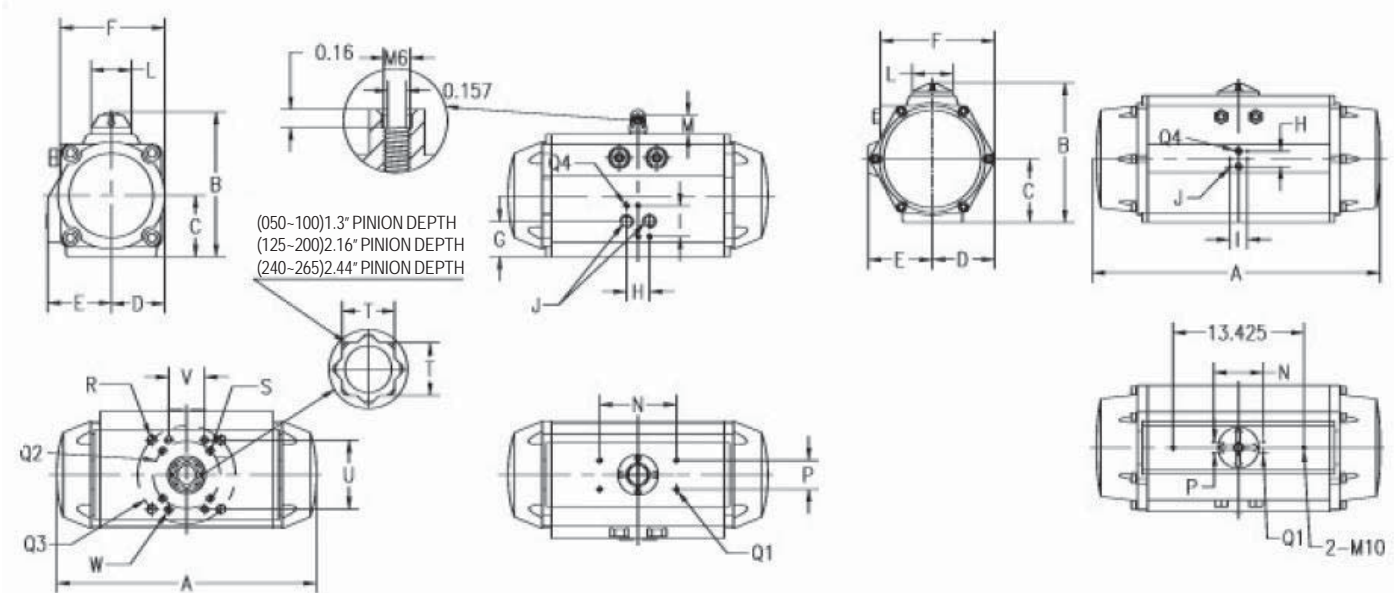

SPN II 050-240

SPN II 265



Model	032	050	063	075	085	100	125	145	160	180	200	240	265
A	4.61	5.8	6.26	8.39	9.80	10.67	13.62	16.22	17.44	19.37	21.54	24.57	29.06
B	1.77	3.62	4.25	4.92	5.43	5.94	7.48	8.25	9.06	9.96	10.91	13.11	14.33
C	X	1.35	1.67	2.01	2.27	2.50	3.09	3.46	3.87	4.33	4.80	5.91	6.50
D	X	1.12	1.42	1.71	1.91	2.20	2.72	3.15	3.46	3.88	4.29	4.84	6.40
E	X	1.61	1.14	2.07	2.22	2.60	3.23	3.54	3.87	4.15	4.41	5.18	6.57
F	1.77	2.28	2.83	3.39	3.80	4.17	5.12	5.85	6.28	7.07	7.64	9.11	11.73
G	X	1.02	1.18	1.03	1.26	1.46	1.80	2.17	2.04	2.37	2.60	3.09	-
H	0.94	0.94	0.94	0.94	0.94	0.94	0.94	0.94	0.94	0.94	0.94	1.57	1.57
I	1.25	1.26	1.26	1.26	1.26	1.26	1.26	1.26	1.26	1.26	1.26	1.77	1.77
J	1/8"	1/4"	1/4"	1/4"	1/4"	1/4"	1/4"	1/4"	1/4"	1/4"	1/4"	3/8"	3/8"
L	1.4	1.65	1.65	1.65	1.65	1.65	2.60	2.60	2.60	3.15	3.15	4.17	4.17
M	0.79	0.79	0.79	0.79	0.79	0.79	0.79	1.18	1.18	1.18	1.18	1.97	1.97
N	1.97	3.15	3.15	3.15	3.15	3.15	3.15	3.15	3.15	5.12	5.12	5.12	5.12
P	1.18	1.18	1.18	1.18	1.18	1.18	1.18	1.18	1.18	1.18	1.18	1.18	1.18
Q1	M5	M5	M5	M5	M5	M5	M5	M5	M5	M5	M5	M5	M5
Q2	1.43	1.65	1.97	1.97	1.97	2.76	4.02	4.02	4.02	4.02	4.02	4.92	-
Q3	X	X	X	2.76	2.76	4.02	X	4.92	4.92	5.51	5.51	6.50	6.50
Q4	M5	M5	M5	M5	M5	M5	M5	M5	M5	M5	M5	M6	M6
R	X	X	X	M8	M8	M10	X	M12	M12	M16	M16	M20	M20
S	M5	M5	M6	M6	M6	M8	M10	M10	M10	M10	M10	M12	-
T	0.35	0.67	0.67	0.87	0.87	0.87	1.42	1.42	1.42	1.42	1.42	1.81	1.81
U	X	X	X	X	X	2.83	2.83	2.83	2.83	3.90	3.90	-	-
V	X	X	X	X	X	1.46	1.46	1.46	1.46	2.09	2.09	-	-
W	X	X	X	X	X	M8	M8	M8	M8	M10	M10	-	-

Actuation Selection Chart

Actuator Sizing Info	2	2 1/2	3	4	5	6	8	10	12	14	16	18	20	24
Seating Torque**	133	211	278	419	648	940	1510	2489	3628	4200	6600	9840	12000	21840
Double Acting*	63DA	63DA	63DA	75DA	85DA	100DA	125DA	145DA	145DA	180DA	180DA	200DA	240DA	265DA
Spring Return*	63SR	75SR	85SR	100SR	125SR	125SR	145SR	180SR	180SR	240SR	240SR	265SR	***	***

* Recommended SPN II piston pneumatic actuators have been sized based on 80 PSI air supply and have been tested utilizing 150 PSI line pressure (water).
 ** All torque values on chart are in/lbs based on 150 PSI differential pressure and are for "wet" (water & other lubricating media) on-off service. For "dry" service (non-lubricating, dry gas media), multiply values by 1.5
 *** Consult supplier
 **** For high or low temperature applications, consult supplier for special seal kits



Limited Warranty

VSTC-09
 EFFECTIVE OCTOBER 1, 2009, TERMS AND CONDITIONS OF SALE WILL APPLY TO ALL PRODUCTS SOLD BY THE VALVSOURCE GROUP OF COMPANIES

CANCELLATIONS & RETURNED PRODUCTS: This policy covers only Products of current manufacture, design, and normally stocked items in new condition. Cancelled orders will be subject to a charge minimum of 35%. All sales are final; all custom products (non-stocking) are not subject to return, credit or refund. The return of obsolete and used Products shall not be permitted. The Purchaser shall not return Products without first obtaining Seller's written permission and shall be subject to a restocking charge. Products must be returned within 10 days after the date that written permission has been given. All transportation charges for any returned Products shall be paid by the Purchaser. Request to return Products must be accompanied by relevant customer order and Seller's invoice number(s). Final acceptance of returned Products is subject to examination and/or testing. Products will not be accepted for return or credit later than six (6) months after invoicing.

NO RIGHTS OF CANCELLATION: The parties acknowledge and agree that the Purchaser shall not have the right to cancel or reject any shipment of Products not delivered within the delivery time specified in this Purchase Agreement. In the event the Purchaser fails or refuses to accept delivery of the Products, Seller shall have the right to cancel this Agreement whereupon all deposit monies paid by Purchaser shall be retained by Seller as liquidated damages and not as penalty and without prejudice to any rights of Seller to claim for all additional costs, expenses and damages Seller may suffer or incur as a result of such cancellation. The Purchaser understands that if the Products described in this Agreement are specially designed and custom built the Seller takes immediate steps upon execution of this Agreement to design order and construct those items set forth herein.

PRICES: Possession of price lists will not be accepted by the Seller as an obligation, or offer, to sell any goods listed therein. All prices contained in published price lists are subject to change without notice and supersede those of all previous lists.

SALES TAXES, ETC.: The Purchaser shall pay and be responsible for all provincial, local or federal sales, use or other taxes (including general sales or value added taxes) and customs duties now or hereinafter enacted which may be applicable to the sale of the Products or the importation of the Products to the destination specified by the Purchaser and which duties and taxes shall be the responsibility of the Purchaser.

CREDIT APPROVAL: Orders are accepted subject to satisfactory credit approval. Pending credit approval, delivery may be delayed without liability to Seller.

TERMS OF PAYMENT: The terms of payment for Products purchased pursuant to this Agreement are (I) upon acceptance of the purchase order a deposit in such amount as may be set out in the Seller's written acceptance notice and (II) the balance within 30 days from the date of invoice. Any invoice amount which is not paid when due shall bear interest at the rate of one and one-half (1 1/2%) percent per month until paid in full. The Purchaser agrees that it will not have any rights of set off against or deduction from the purchase price for the Products payable by the Purchaser pursuant to this Agreement. The Purchaser grants to Seller a purchase money security interest in all Products delivered pursuant to this Agreement and all proceeds thereof (whether cash or non-cash and including, without limitation, accounts, instruments and chattel paper). Any failure by the Purchaser to pay the purchase price in full as provided in this Agreement shall constitute an event of default for purposes of said security interest. Upon the occurrence of any such default, Seller shall have all rights of a secured party after default under applicable law. Any repossession and removal of any Products shall be without prejudice to any of Seller's other remedies at law or in equity. The Purchaser agrees, without further consideration, at any time, to do or cause to be done, to execute and deliver, all such further acts and instruments (including, without limitation, financing statements approved for filing) as Seller may reasonably request in order to perfect Seller's security interest.

DELIVERY DATE: Seller will utilize reasonable best efforts to meet the delivery schedules stipulated in this Agreement. In the event the provisions of Section 13 hereof shall apply, the delivery date shall be extended by a number of days that is equal to the duration of the event or condition that is responsible for such delay.

F.O.B. AND SHIPMENT: Seller shall deliver the Products to the Purchaser F.O.B. Seller's warehouse. Risk of loss of or damage to the Products shall pass to the Purchaser at the F.O.B. point upon transfer of possession to the carrier for delivery to the Purchaser. Loss of or destruction of or damage to the Products from and after the time they are received by the carrier for delivery to the Purchaser shall not in any way release, reduce or in any way affect the Purchaser's responsibility to pay the full purchase price thereof in accordance with the provisions of this Agreement. Seller is not responsible for its selection of the carrier or the mode of shipment.

INSPECTION BY PURCHASER: All Products must be inspected by the Purchaser upon receipt and the Purchaser and Seller, collectively, agree to file appropriate claims with the carrier when there is evidence of shipping damage, either concealed or external. Claims for shortage or error in shipment or for damage other than shipping damage must be made within 5 days after receipt of shipment, failing which the Purchaser shall be deemed to have accepted the shipment.

LIMITED WARRANTY: Purchaser acknowledges that the Products are provided to the Purchaser subject only to the limited warranties provided by the manufacturer of the Products and are subject to all of the conditions, limitations and exclusions set out therein, all of which are hereby accepted by the Purchaser. The warranty exclusions include, without limitation, (I) any defects caused by faulty installation performed by Purchaser or third parties, (II) any damage caused by the contractors or tradesman of the Purchaser, (III) any damage caused by improper use or misuse, including exposure to excessive temperatures, moisture or cleaning agents and solvents and (IV) any damage caused during transportation or improper storage. Claims for warranty repairs and replacements must be made within the applicable time period described in the manufacturer's limited warranty. In no event shall Seller be liable for other than the repair or replacement of any defective Products. In no event shall Seller be liable for any damages, direct or indirect, special or consequential, including, without limitation, damages for lost profits, business interruption, or economic loss arising out of defects in the Products.

EXCLUSION OF WARRANTIES: Except as expressly set forth herein seller disclaims all warranties with regard to the products including, without limitation, all implied warranties of merchantability and fitness for a particular purpose.

CATALOGUE AND OTHER PRINTED MATTER: Seller's illustrations are representations of a certain size of each line of Product, but do not necessarily represent all sizes and materials in detail. Similarly, dimensions, weights and material information have been prepared with care, but their correctness is not guaranteed. Seller reserves the right to vary the designs and dimensions without notice.

FORCE MAJEURE: Any delay or failure of performance by Seller shall be excused if and to the extent caused, directly or indirectly, events beyond Seller's control including, without limitation, fire, flood earthquake, lightning, hurricane, explosion, accident or breakdown, acts of God, embargo, strike, labour dispute, labour trouble, lockout, shortage or control of power supply, shortage of supplies or raw materials, or any causes whether of the same kind as the causes enumerated before or not. Subject to any express provisions of this Agreement, any such causes of delay shall extend the time of performance by the length of delay occasioned thereby.

NO WAIVER: No waiver by Seller of any right hereunder or of any right granted in connection with a failure to perform or breach by the Purchaser shall be deemed as a waiver of any other right hereunder or of any right granted in connection with any other failure or breach by the Purchaser, whether of a similar nature or otherwise.

NOTICE: Any notice made under or in relation to this Agreement shall be sent to the addresses first above written or such other address as the intended recipient shall have previously designated by written notice, by postage prepaid registered mail or by telegram including telex, followed by a confirmation letter by post prepaid and return receipt requested registered mail. The notice shall be deemed to be made on the fifth day following the date of mailing.

ENTIRE AGREEMENT: This Agreement contains the entire agreement and understanding of the parties hereto with respect to the subject matter of this Agreement, and supersedes all prior discussions, agreements, understandings of any and every nature, whether written or oral, between the parties with respect to the subject matter of this Agreement, and no condition, definition, warranty or representation other than those expressly provided for in this Agreement with respect to the subject matter of this Agreement shall be binding upon either party hereto.

AMENDMENTS IN WRITING: Any amendment, modification, change or alteration of this Agreement shall be made in writing which expressly refers to this Agreement and which is signed by a duly authorized officer or representative of each of the parties hereto.

SEVERABILITY: All provisions of this Agreement are severable and this Agreement shall be interpreted and enforced as if all completely invalid or unenforceable provisions were not contained herein. All partially valid and enforceable provisions shall be enforced to the extent they are valid and enforceable.

NO AGENCY OR PARTNERSHIP: Nothing herein contained shall be deemed or construed to constitute either party the agent or partner of the other. Neither party shall have any right, title or authority to enter into any contract, agreement or commitment on behalf of the other or to bind the other in any manner whatsoever.

GOVERNING LAW: This agreement shall be governed by and construed in accordance with the laws of the jurisdiction from which the products are shipped by the seller to the purchaser and the parties hereby attorn to the courts of such jurisdiction.

ENUREMENT: This Agreement shall enure to the benefit of and be binding upon the parties hereto and on their successors and permitted assigns.

SELLER DEFINED: For the purposes hereof, Seller means the Corporation listed as such on the front page of the Invoice or acceptance notice of which these terms and conditions of sale form a part.

Contact Information

Your local Sales Representative:

In accordance with our policy to strive for continuous improvement of the product, we reserve the right to alter the dimensions, technical data and information included in this catalogue when required.
 Flow+ Butterfly Valve Brochure 01/70

Flow+ Butterfly Valves



Quality Valves at Low Cost



How to Order

- 1
- 2
- 3
- 4
- 5
- 6
- 7
- 8
- 9
- 10

Note: for Sanitary Butterfly Valves, please see the Flow+ Price List

- 1 (Size):** 02 = 2"
25 = 2-1/2"
03 = 3"
up to
48 = 48"
- 2 (Style):** A = Wafer (ANSI 125/150)
B = Wafer (ANSI 125/150, DIN PN10/PN16)
C = Lug (ANSI 125/150)
- 3 (Body):** 1 = Cast Iron
2 = Ductile Iron
3 = Carbon Steel
4 = Stainless Steel
- 4 (Pressure):** 0 = 232 PSI (2" - 12")
2 = 285 PSI (2" - 12")
4 = 250 PSI (14" & up)
8 = 125 PSI (2" & up)
- 5 (Disc):** 2 = Nickel Plated Ductile Iron
3 = Aluminum Bronze
4 = 316SS
5 = Alloy 20
6 = Monel
7 = Hastelloy C
8 = Nylon Coated Ductile
9 = PTFE Coated 316SS
- 6 (Shaft):** 1 = 416SS / 431SS/304SS
4 = 316SS
5 = 17-4SS
- 7 (Bushings):** 0 = Bronze
3 = PTFE
- 8 (Seat/Liner):** 1 = Buna-N
5 = EPDM
6 = Viton
8 = Hypalon
9 = PTFE Lined EPDM (125 PSI Rated Only)
- 9 (Actuator):** 3 = Memory-Stop / Lockable Handle (2" - 8")
5 = Gear Operator
6 = Double Acting Actuator
7 = Fail Close Actuator
8 = Fail Open Actuator
9 = Electric Actuator
C = Buried Gear / 2" Nut
U = Chain Wheel
X = None
- 10 (Special Features):** 0 = Custom Product

2" - 12" Butterfly Valve

Maximum Working Pressure 285 PSI

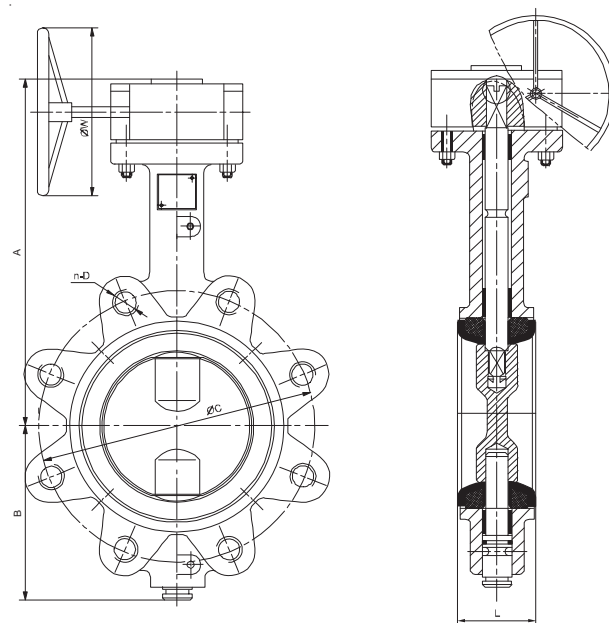

	Material	ASTM
Body	Ductile Iron	A395
	Cast Iron	A126-B
	Carbon Steel*	A216
	Stainless Steel*	A351-CF8M
Disc	Ductile Iron - Nickel Plated	A395-ENP
	316 Stainless Steel	A351-CF8M
	Aluminum Bronze*	A339-80-45-10
	Alloy 20*	A351-CN-7M
	Monel*	A494-M35
	Hastelloy C-276*	A494-CW-6M
	316 Stainless Steel*	A182-F316
Shaft	416 Stainless Steel	A582
	17-4 Stainless Steel	A564
	Bronze*	B62
Bushings	PTFE	N/A
	Temperature	
Seat/Liner	Buna-N	0 - 180 Deg. F / (-18 Deg.) - 80 Deg. C
	EPDM	(-30 Deg.) - 275 Deg. F / (-35 Deg.) - 135 Deg. C
	Viton	0 Deg. - 400 Deg. F / (-18 Deg.) - 204 Deg. C
	PTFE Lined EPDM (125 PSI Rated Only)	0 - 250 Deg. F / (-18 Deg.) - 120 Deg. C
	Hypalon*	(-20 Deg.) - 200 Deg. F / (-30 Deg.) - 90 Deg. C

* Optional Equipment

Note: for Sanitary Butterfly Valves, please see the Flow+ Price List

SIZE	A	B	C	D	n-d	E	L	W
2"	194	89	120.5	19	4-5/8-11UNC-2B	85.2	46.1	267
2.5"	206	98	139.5	19	4-5/8-11UNC-2B	98.6	49.1	267
3"	213	104	152.5	19	4-5/8-11UNC-2B	107.8	48.4	267
4"	232	123	190.5	19	8-5/8-11UNC-2B	72.9	55.3	267
5"	244	136	216	22	8-3/4-10UNC-2B	82.7	58.8	356
6"	257	147	241.5	22	8-3/4-10UNC-2B	92.4	59.1	356
8" Lever	246	184	298.5	22	8-3/4-10UNC-2B	114.2	64.1	369
8" Gear	332	184	298.5	22	8-3/4-10UNC-2B	114.2	64.1	296
10"	364	212	362	25	12-7/8-9UNC-2B	93.7	71.8	296
12"	414	255	432	25	12-7/8-9UNC-2B	111.8	81	296

*units of measure: millimeters

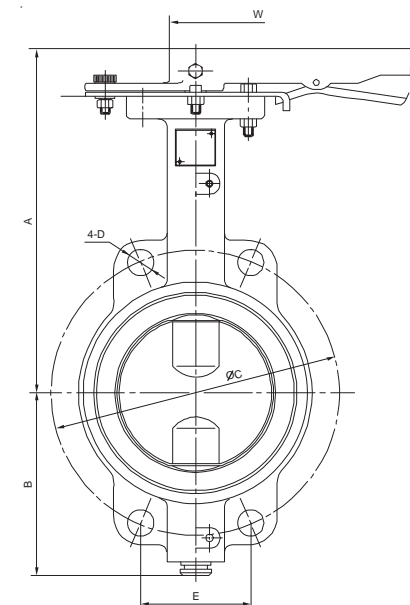

Features

- Available in Wafer or Lug Body
- Bubble tight and Bi-directional to 285 PSI
- Consult supplier for vacuum service
- Standard dead-end service for lug style with downstream flange removed
- Compatible with ASME 125/150 flanges
- Applicable standards; API 609, MSS-SP67, tested per API-598, Canadian Registration Number (CRN)
- Phenolic backed seat provides dimensionally stable seat sealing surface, minimal seat wear and extending seat life
- Seats are easily field replaceable
- Blow-out proof design
- All valve bodies are epoxy coated
- ISO 5211 mounting flange allowing easy actuation
- Locking lever handle with 10 position notch plate and memory stop on sizes 2" - 8", gear operator available on request
- Gear operator with handwheel on sizes 8" - 12", handle operator available on request
- Actuation available to suit any requirement



14" - 24" Butterfly Valve

Maximum Working Pressure 250 PSI

For information on sizes over 24" consult supplier

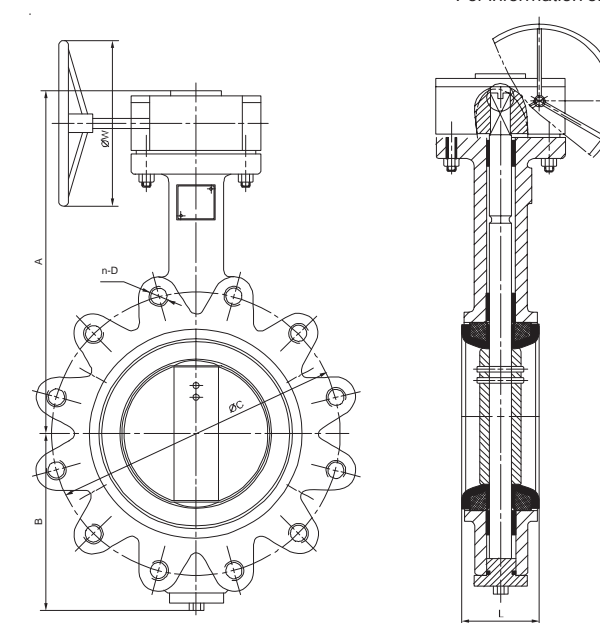

Part	Material	ASTM
Body	Ductile Iron	A395
	Cast Iron	A126-B
	Carbon Steel*	A216
	Stainless Steel*	A351-CF8M
Disc	Ductile Iron - Nickel Plated	A395-ENP
	316 Stainless Steel	A351-CF8M
	Aluminum Bronze*	A339-80-45-10
	Alloy 20*	A351-CN-7M
	Monel*	A494-M35
	Hastelloy C-276*	A494-CW-6M
	316 Stainless Steel*	A182-F316
Shaft	416 Stainless Steel	A582
	17-4 Stainless Steel	A564
	Bronze*	B62
Bushings	PTFE	N/A
	Temperature	
Seat/Liner	Buna-N	0 - 180 Deg. F / (-18 Deg.) - 80 Deg. C
	EPDM	(-30 Deg.) - 275 Deg. F / (-35 Deg.) - 135 Deg. C
	Viton	0 Deg. - 400 Deg. F / (-18 Deg.) - 204 Deg. C
	PTFE Lined EPDM (125 PSI Rated Only)	0 - 250 Deg. F / (-18 Deg.) - 120 Deg. C
	Hypalon*	(-20 Deg.) - 200 Deg. F / (-30 Deg.) - 90 Deg. C

* Optional Equipment

SIZE	A	B	C	n-d	L	W
14"	445	267	476	12-1-8UN-2B	79.5	299
16"	505	322	539.5	16-1-8UN-2B	90	299
18"	527	339	578	16-1-1/8-8UN-2B	109	300
20"	600	371	635	20-1-1/8-8UN-2B	135	300
24"	682	461	749.5	20-1-1/4-8UN-2B	156	300

*units of measure: millimeters

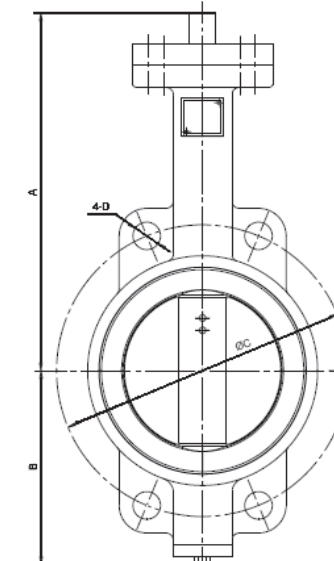

Features

- Available in Wafer or Lug Body
- Bubble tight and Bi-directional to 250 PSI
- Consult supplier for vacuum service
- Standard dead-end service for lug style with downstream flange removed
- Compatible with ASME 125/150 flanges
- Applicable standards; API 609, MSS-SP67, tested per API-598, Canadian Registration Number (CRN)
- Phenolic backed seat provides dimensionally stable seat sealing surface, minimal seat wear and extending seat life
- Seats are easily field replaceable
- Blow-out proof design
- All valve bodies are epoxy coated
- ISO 5211 mounting flange allowing easy actuation
- Gear operator with handwheel on sizes 14" - 24"
- Actuation available to suit any requirement

Cv Value* - Valve Sizing Coefficient

Disc Angle Open°	Valve Size													
	2	2 1/2	3	4	5	6	8	10	12	14	16	18	20	24
10°	0.1	0.2	0.3	0.5	0.8	2	3	4	5	6	8	11	14	22
20°	5	8	12	17	29	45	89	151	234	338	464	615	791	1222
30°	12	20	23	36	61	95	188	320	495	715	983	1302	1647	2587
40°	15	25	39	78	133	205	408	694	1072	1549	2130	2822	3628	5605
50°	27	45	70	139	237	366	727	1237	1911	2761	3797	5028	6465	9989
60°	44	75	116	230	392	605	1202	2049	3162	4568	6282	8320	10698	16528
70°	70	119	183	364	620	958	1903	3240	5005	7230	9942	13168	16931	26157
80°	105	178	275	546	930	1437	2854	4859	7507	10844	14913	19752	25396	39236
90°	115	196	302	600	1022	1579	3136	5430	8250	11917	16388	21705	27908	43116

Cv Value - USGPM water @ 70F passed through the valve with 1 PSI pressure drop

Technical Information

Weights		Valve Size													
Bare Stem		2	2 1/2	3	4	5	6	8	10	12	14	16	18	20	24
Wafer	lb	6	7	10	13	18	20	32	42	70	95	117	165	275	440
	kg	2.72	3.18	4.54	5.90	8.16	9.07	14.51	19.05	31.75	43.09	53.07	74.84	124.74	199.58
Lug	lb	7	8	14	26	28	31	49	72	105	155	195	230	396	610
	kg	3.18	3.63	6.35	11.79	12.70	14.06	22.23	32.66	47.63	70.31	88.45	104.33	179.62	276.70
Lever Operated		2	2 1/2	3	4	5	6	8	10	12	14	16	18	20	24
Wafer	lb	7.8	8.8	11.8	14.8	19.8	21.8	36	46	74	-	-	-	-	-
	kg	3.52	3.98	5.34	6.70	8.96	9.87	16.31	20.85	33.55	-	-	-	-	-
Lug	lb	8.8	9.8	15.8	27.8	29.8	32.8	53	76	109	-	-	-	-	-
	kg	3.98	4.43	7.15	12.59	13.5	14.86	24.03	34.46	49.43	-	-	-	-	-
Gear Operated		2	2 1/2	3	4	5	6	8	10	12	14	16	18	20	24
Wafer	lb	33.1	34.1	37.1	40.1	45.1	47.1	63.7	73.7	101.7	126.7	194.4	242.4	352.4	517.4
	kg	15.02	15.48	16.84	18.2	20.46	21.37	28.91	33.45	46.15	57.49	88.27	110.04	159.94	234.78
Lug	lb	34.1	35.1	41.1	53.1	55.1	58.1	80.7	103.7	136.7	186.7	272.4	307.4	473.4	687.4
	kg	15.48	15.93	18.65	24.09	25	26.35	36.63	47.06	62.03	84.71	123.65	139.53	214.82	311.90