

TOM WHEATLEY™ Piston Check Valves

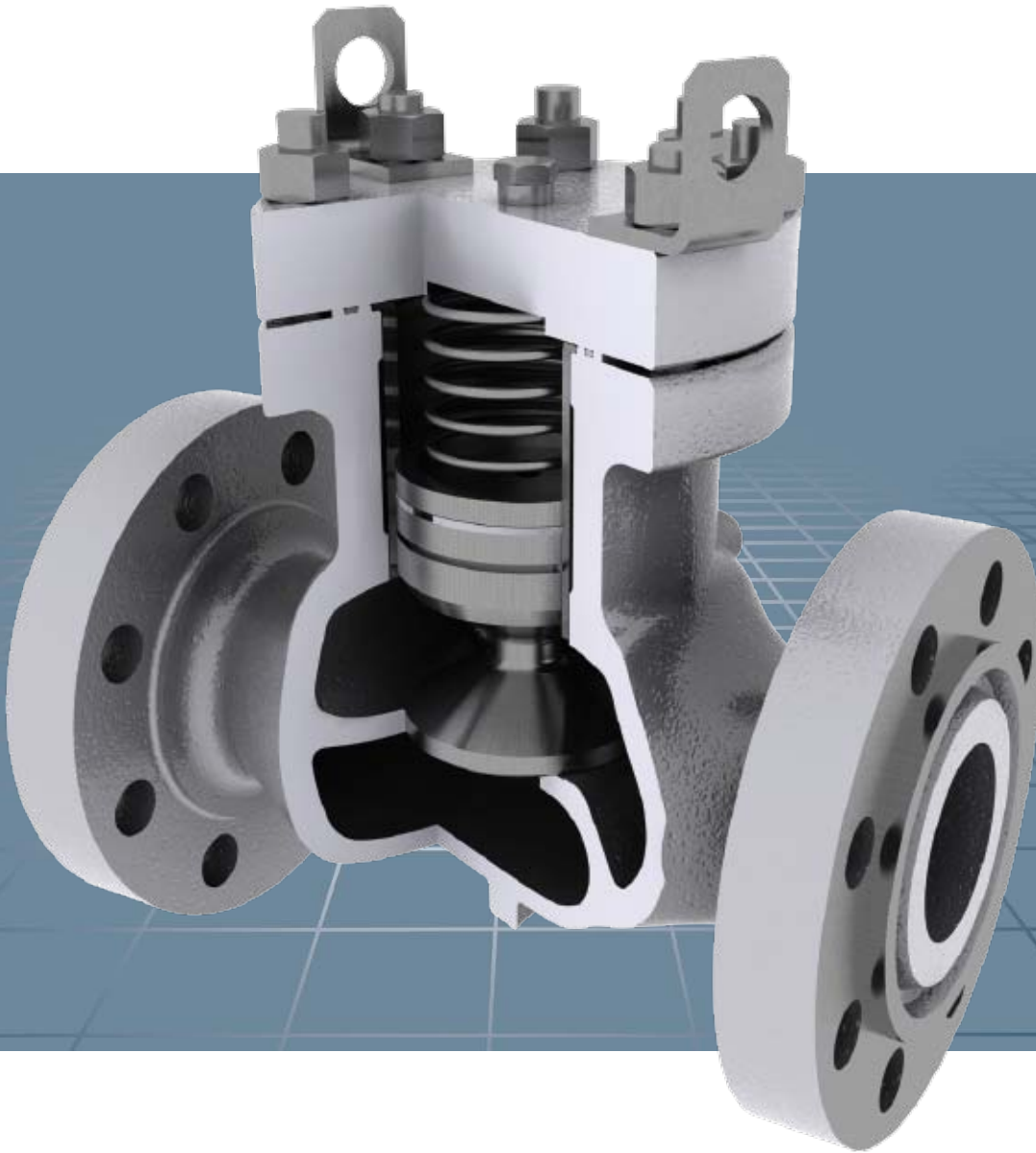

TOM WHEATLEY™

TABLE OF CONTENTS

TOM WHEATLEY™ PISTON CHECK VALVES

Introduction.....	4
Features.....	5
Installation & Operation	6
How to Order	7
Assembly & Disassembly	8
Dimensions Raised Face Flanged End.....	9
Dimensions Ring Joint Flanged End	10
Standard Materials of Construction.....	11
Pressure Loss Curves & Flow Coefficients	12
Aftermarket Services.....	13
Trademark Information	14



Oklahoma City, OK

Cameron's Valves & Measurement (V&M) group is a leading provider of valves and measurement systems to the oil and gas industry. The group's products are primarily used to control, direct and measure the flow of oil and gas as it is moved to refineries, petrochemical plants and industrial centers for processing.

The Distributed Valves division provides valves products that are sold through distributor networks worldwide, for use in both oil and gas and industrial applications and include such widely recognized brand names as DEMCO®, NAVCO®, NUTRON®, THORNHILL CRAVER®, TECHNO®, TOM WHEATLEY®, WHEATLEY® and WKM®.

TOM WHEATLEY is recognized for its use in pipelines, production and process applications. The valves are applied primarily in gas compression applications. Non-slam valves prevent reverse flow. Their short stroke length reduces closing time, and eliminates water hammer.

TOM WHEATLEY™ PISTON CHECK VALVES

2 IN. (50 MM) THROUGH 12 IN. (300 MM) ASME CLASS 150 - 1500

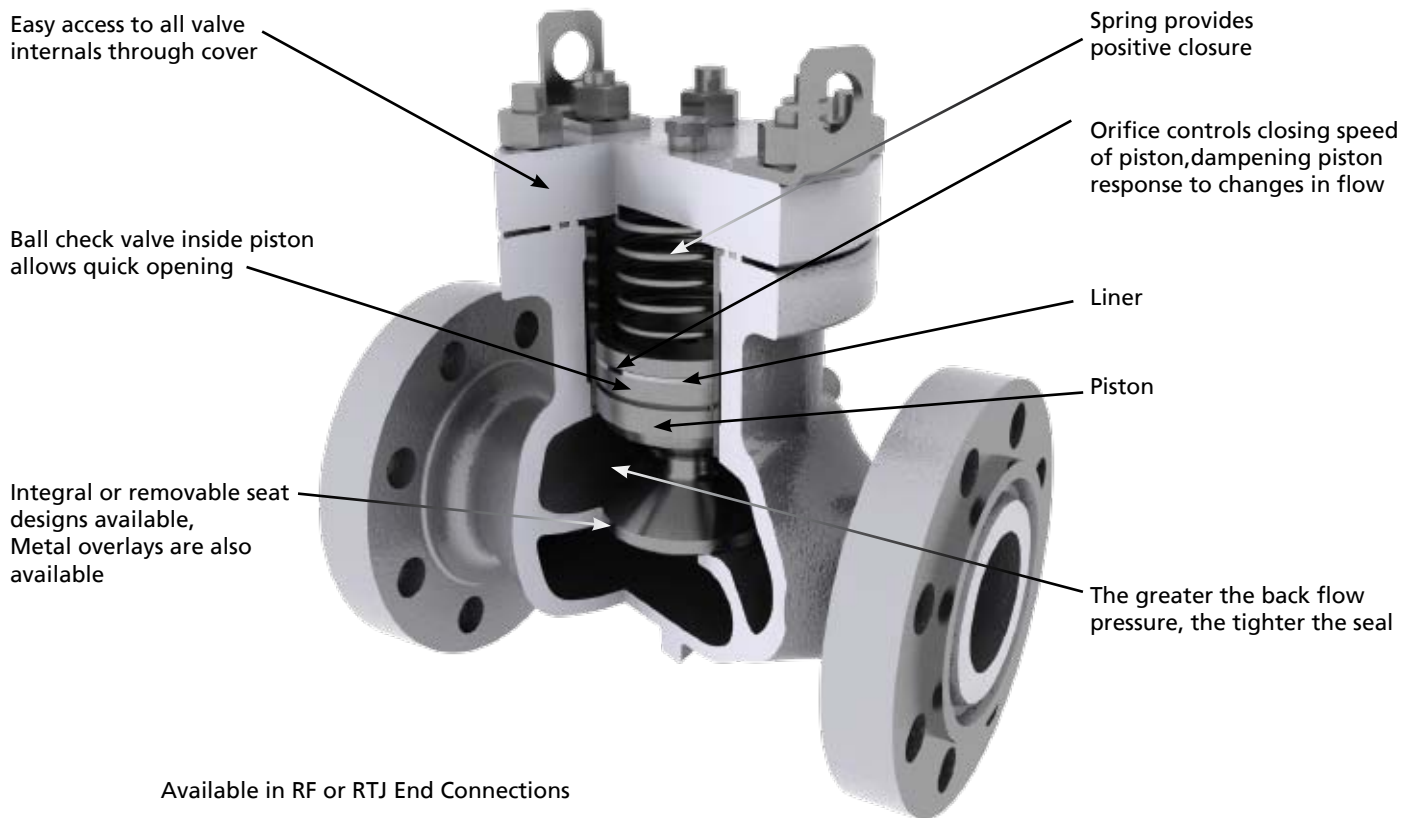

When pressure surges and pulsations are prevalent in a flow system, TOM WHEATLEY piston Check valves are an efficient solution to system protection.

Due to a unique non-slam design, TOM WHEATLEY Piston Check valves have provided years of uninterrupted service downstream from reciprocating pumps and compressors and in other applications where conventional check valve designs would be subjected to excessive wear. In addition, the TOM WHEATLEY Piston Check valve top entry design allows for easy access and replacement of all valve internals with minimal downtime.

Smooth, Reliable Prevention of Backflow

In the absence of pressure differential, a TOM WHEATLEY Piston Check valve rests in the closed position due to gravity and spring force. Pressure on the upstream end of the valve lifts the piston off the seat and allows flow. As flow varies, the piston of the TOM WHEATLEY Piston Check valve floats within a cylinder. Should the flow cease, the piston lowers and seats to create a bubble-tight prevention of backflow.

A ball check mechanism and an adjacent orifice within the piston extend valve life by dampening piston movement and eliminating slamming or chattering in the event of sudden pressure surges or erratic flow conditions.

The orifice size affects the degree of piston movement and is optimally selected at the factory to meet the requirements of a specified flow range.

The TOM WHEATLEY Piston Check valve is available with the following features:

- Soft seal
- Metal-to-metal seal
- Renewable seat
- A variety of body and trim materials

As a result of the piston and seat design the greater the back pressure acting on the piston the tighter the seal.

TOM WHEATLEY Piston Check valves complies with API 6D (ISO 14313), ASTM B 16.34, NACE MR0175/15156 and all TOM WHEATLEY Piston Check valves are designed for horizontal service. TOM WHEATLEY Piston Check valves must be specifically ordered for vertical flow up when intended for that service.

TOM WHEATLEY™ PISTON CHECK VALVES

HOW TO ORDER

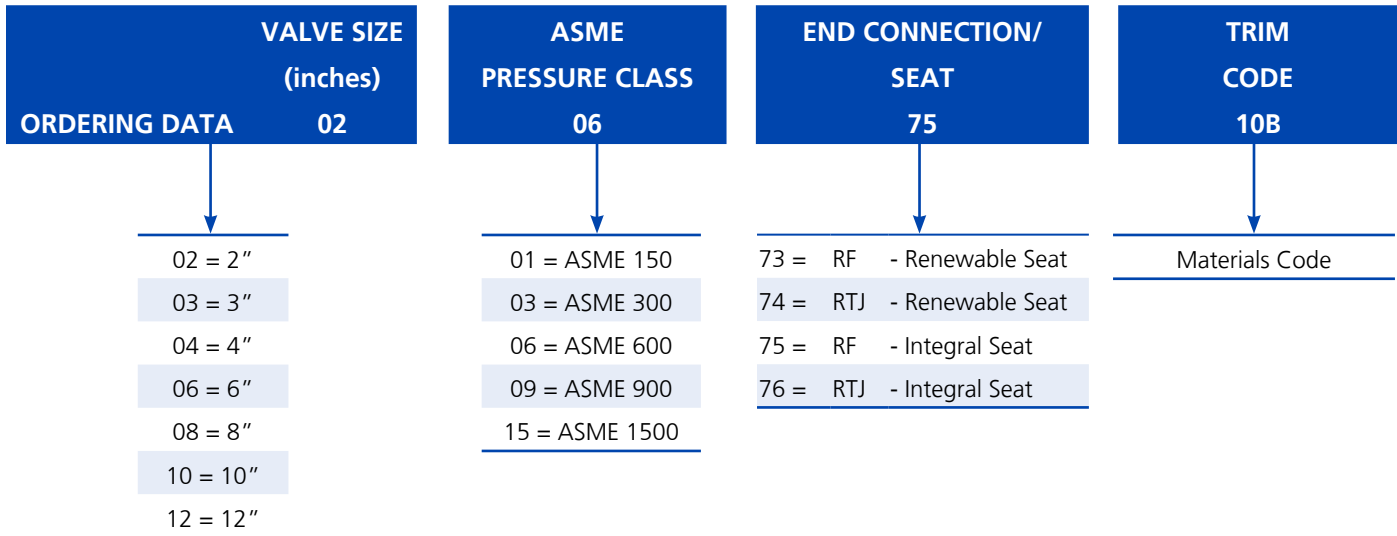

Materials Code - See Standard Materials of Constructions
The Alpha Character Represents the Seal Material Code

Body	ASTM A216 Gr. WCC
Cover	A516 Gr. 70
Cover Seal	Buna-N
Bolting	ASTM A193 Gr. B7, ASTM A194 Gr. 2H
Liner	ASTM A29-1018 with ENP
Piston	410 Stainless Steel
Piston Seal	Buna-N
Seat	Integral
Piston Rings	Cast Iron

Note: Other materials of construction and seals available upon request.

TOM WHEATLEY™ PISTON CHECK VALVES

2 IN. (50 MM) THROUGH 12 IN. (300 MM) ASME CLASS 150 - 1500

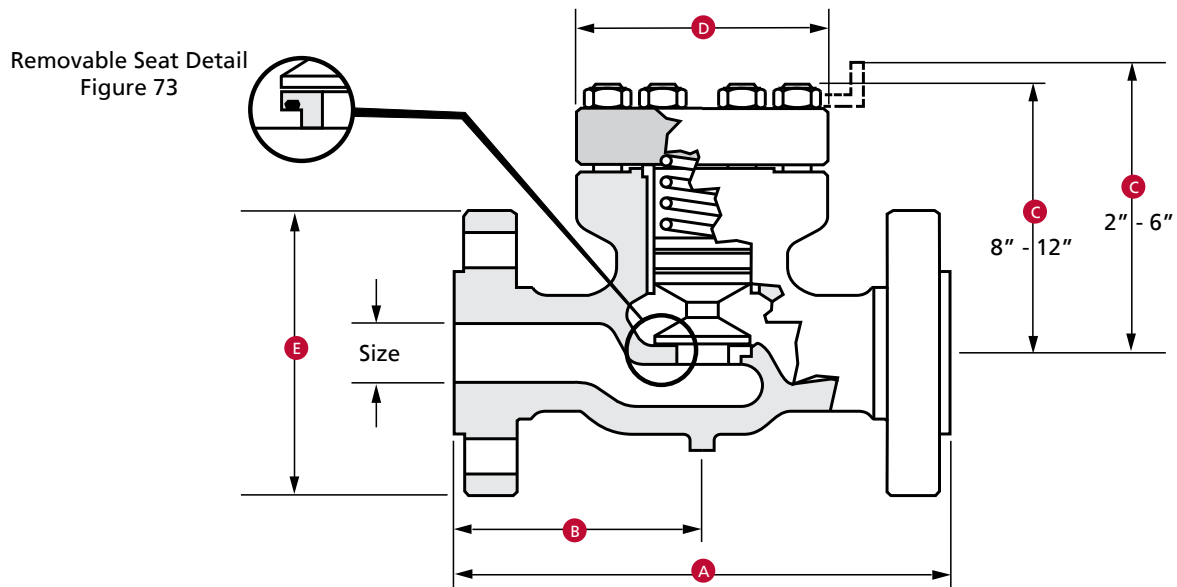

DIMENSIONS

NOMINAL SIZE in. (mm)	ASME CLASS	A (RF)	A (RTJ)	B	C	D	E
2 (50)	150	10.50 (267)*	11.13 (283)*	5.25 (134)	9.25 (235)	7.00 (178)	6.00 (152)
	300	10.50 (267)	11.13 (283)	5.25 (134)	9.25 (235)	7.00 (178)	6.50 (165)
	600	11.50 (292)	11.63 (295)	5.75 (146)	9.50 (241)	7.00 (178)	6.50 (165)
	900	14.50 (368)	14.63 (372)	7.25 (184)	10.00 (254)	7.63 (194)	8.50 (216)
	1500	14.50 (368)	14.63 (372)	7.25 (184)	10.25 (260)	7.63 (194)	8.50 (216)
3 (80)	150	12.50 (318)*	13.13 (334)*	6.25 (159)	10.75 (273)	8.25 (210)	7.50 (191)
	300	12.50 (318)	13.13 (334)	6.25 (159)	10.75 (273)	8.25 (210)	8.25 (210)
	600	14.00 (356)	14.13 (359)	7.00 (178)	11.13 (283)	8.25 (210)	8.25 (210)
	900	15.00 (381)	15.13 (384)	7.50 (191)	11.38 (289)	8.25 (210)	9.50 (241)
	1500	18.50 (470)	18.63 (473)	9.25 (235)	13.13 (334)	11.63 (295)	10.50 (267)
4 (100)	150	14.00 (356)*	14.63 (372)*	7.00 (178)	11.50 (292)	9.75 (248)	9.00 (229)
	300	14.00 (356)	14.63 (372)	7.00 (178)	11.50 (292)	9.75 (248)	10.00 (254)
	600	17.00 (432)	17.13 (435)	8.50 (216)	11.88 (302)	9.75 (248)	10.75 (273)
	900	18.00 (457)	18.13 (461)	9.00 (229)	12.37 (314)	9.75 (248)	11.50 (292)
	1500	21.50 (546)	21.63 (549)	10.75 (273)	13.00 (330)	10.75 (273)	12.25 (311)
6 (150)	150	17.50 (445)*	18.13 (461)*	8.75 (223)	16.38 (416)	11.75 (298)	11.00 (279)
	300	17.50 (445)	18.13 (461)	8.75 (223)	16.38 (416)	11.75 (298)	12.50 (318)
	600	22.00 (559)	22.13 (562)	11.00 (280)	17.07 (434)	12.25 (311)	14.00 (356)
	900	24.00 (610)	24.13 (613)	12.00 (305)	17.25 (438)	11.75 (298)	15.00 (381)
	1500	27.75 (705)	28.00 (711)	13.88 (353)	15.75 (400)	13.13 (334)	15.50 (394)
8 (200)	150	19.50 (495)	20.00 (508)	9.75 (248)	13.00 (330)	14.75 (375)	13.50 (343)
	300	21.00 (533)	21.63 (549)	10.50 (267)	13.88 (352)	14.75 (375)	17.50 (445)
	900	29.00 (737)	29.13 (740)	14.50 (368)	15.13 (384)	14.69 (373)	18.50 (470)
10 (250)	150	24.50 (622)	25.00 (635)	12.25 (311)	15.38 (391)	17.50 (445)	16.00 (406)
	300	24.50 (622)	25.13 (638)	12.25 (311)	15.38 (391)	17.50 (445)	17.50 (445)
	600	31.00 (787)	31.13 (791)	15.50 (394)	16.38 (416)	17.50 (445)	20.00 (508)
	900	33.00 (838)	33.13 (842)	16.50 (419)	16.88 (429)	17.50 (445)	21.50 (546)
12 (300)	150	27.50 (699)	28.00 (711)	13.75 (349)	18.50 (470)	21.00 (533)	19.00 (483)
	300	28.00 (711)	28.63 (727)	14.00 (356)	18.50 (470)	21.00 (533)	20.50 (521)
	600	33.00 (838)	33.13 (842)	16.50 (419)	18.26 (464)	21.00 (533)	22.00 (559)
	900	38.00 (965)	38.13 (969)	19.00 (483)	19.13 (486)	21.00 (533)	24.00 (610)

* Length exceeds dimensions given in API 6D/ISO 14313.

TOM WHEATLEY™ PISTON CHECK VALVES

2 IN. (50 MM) THROUGH 12 IN. (300 MM) ASME CLASS 150 - 1500
STANDARD MATERIALS OF CONSTRUCTION

PART	STANDARD TRIM 10X	STAINLESS SEATS TRIM 20X	FULL STAINLESS TRIM 30X	METAL-TO-METAL TRIM 40X	STELLITE SEATS TRIM 50X
Body	A216-WCC	A216-WCC	A351-CF8M	A216-WCC	A216-WCC
Cover	ASTM A515 Gr. 70	ASTM A515 Gr. 70	A240-316	ASTM A515 Gr. 70	ASTM A515 Gr. 70
Cover Seal	Buna	Buna	Buna	RTJ	Buna
Bolting	A193-B7, A194-2H	A193-B7 A194-2H	A193-B7M A194-8M	A193-B7 A194-2H	A193-B7 A194-2H
Liner	A29-1018 ENP	A29-1018 ENP	A276-316 EHC	A29-1018 ENP	A29-1018 ENP
Piston	410 SS	410 SS	316 SS	410 SS	410 SS with Stellite #6 hard face
Piston Seal	See Note 1	See Note 1	See Note 1	See Note 1	See Note 1
Seat Integral	A216-WCC	N/A	A351-CF8M	A216 WCC	N/A
Seat Renewable	Carbon Steel	316 SS	316 SS	Carbon Steel	410 SS with Stellite #6 hard face
Piston Rings	Cast Iron	Cast Iron	Cast Iron ENP	Cast Iron	Cast Iron
Piston Spring	Alloy X750	Alloy X750	Alloy X750	Alloy X750	Alloy X750

Notes:

- In the Trim Number Description "X" relates to standard Piston Seal Material Options. When ordering a valve substitute one of the following for "X":

- B = Buna-N
- V = Viton
- T = Teflon
- M = Metal-to-Metal
- H = HSN
- F = Fiber

Other seal material options are available upon request.

- N/A = Not available.
- Valves with O-ring cover seals the seal material will be the same as the piston seal material.
- ENP = Electroless Nickel Plated.
- EHC = Engineered Hard Chrome Plating.
- Materials comply with NACE MR0175 / ISO 15156.
- Other materials are available upon request.

TOM WHEATLEY™ PISTON CHECK VALVES

2 IN. (50 MM) THROUGH 12 IN. (300 MM) ASME CLASS 150 - 1500
PRESSURE LOSS CURVES/FLOW COEFFICIENTS

Pressure Loss Curves For Piston Check Valves

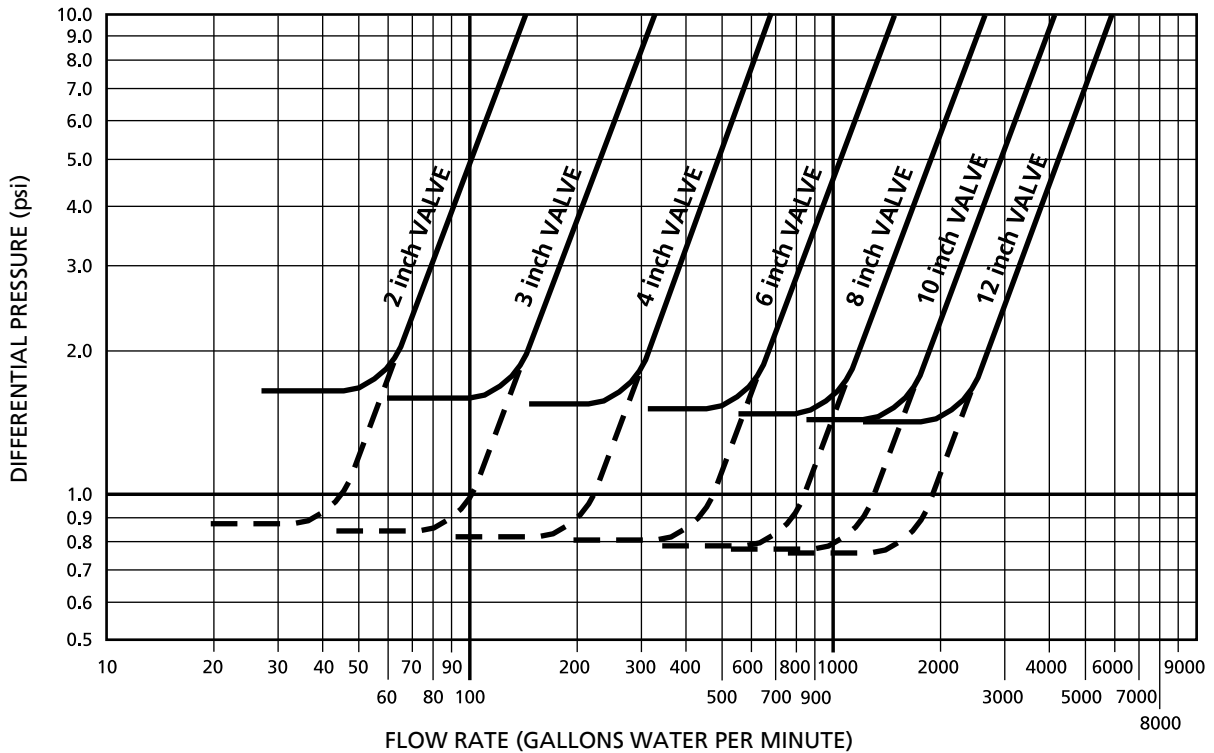

Dotted lines represent pressure loss for valves without springs

Flow Coefficients (C_v)
Full Open Valves

VALVE SIZE	C_v
2	46
3	104
4	212
6	477
8	848
10	1325
12	1908

Gas (Compressible Flow)

$$C_v = \frac{Q}{963} \sqrt{\frac{GT}{P_1^2 - P_2^2}}$$

$$Q = C_v 963 \sqrt{\frac{P_1^2 - P_2^2}{GT}}$$

Liquid (Incompressible Flow)

The equations listed below are the basis for the above nomogram. The nomogram is a method for solving the equations below quickly and simply when service fluid is water.

$$C_v = Q \sqrt{\frac{G}{\Delta P}} \quad Q = C_v \sqrt{\frac{\Delta P}{G}} \quad \Delta P = \left[\frac{Q}{C_v} \right]^2 G$$

Where:

Q = FLOW LIQUIDS-GPM
GASES-SCFH

C_v = FLOW COEFFICIENT

P_1 = INLET PRESSURE (psia)

P_2 = OUTLET PRESSURE (psia)

ΔP = PRESSURE DROP ($P_1 - P_2$)

T = ABSOLUTE TEMPERATURE ($^{\circ}F + 460$)

G = SPECIFIC GRAVITY (WATER = 1)

CAMSERV™ AFTERMARKET SERVICES



Cameron's Aftermarket Services' goal is to help our customers lower the total cost of valve ownership. To that end we offer a full range of services from over twenty-five Service Centers worldwide and can provide experienced personnel trained to meet the specific service requirements of each valve type.

Aftermarket Services

- Supplies replacement valves and parts:
 - Maintains a full inventory of new and reconditioned valves for immediate delivery
 - Provides factory warranty support for all Cameron OEM brands as well as service for most other valves
- Field Service & Technical Support
 - Field service technicians on call 24 hours a day 7 days a week to handle service issues wherever they arise
 - Provides equipment installation, field repairs, as well as track and perform scheduled maintenance
- Customer Property Repair
 - The Customer Property Repair program allows Cameron valve customers to store assets at our service centers throughout the world
 - Valves tracked in electronic database accessible through the Internet
- Remanufactured Products
 - Offers a broad range of API-compliant reconditioned equipment with fast delivery
- Total Valve Management
 - Supply and service automation and control packages
 - Assist with valve installation, commissioning and start-up

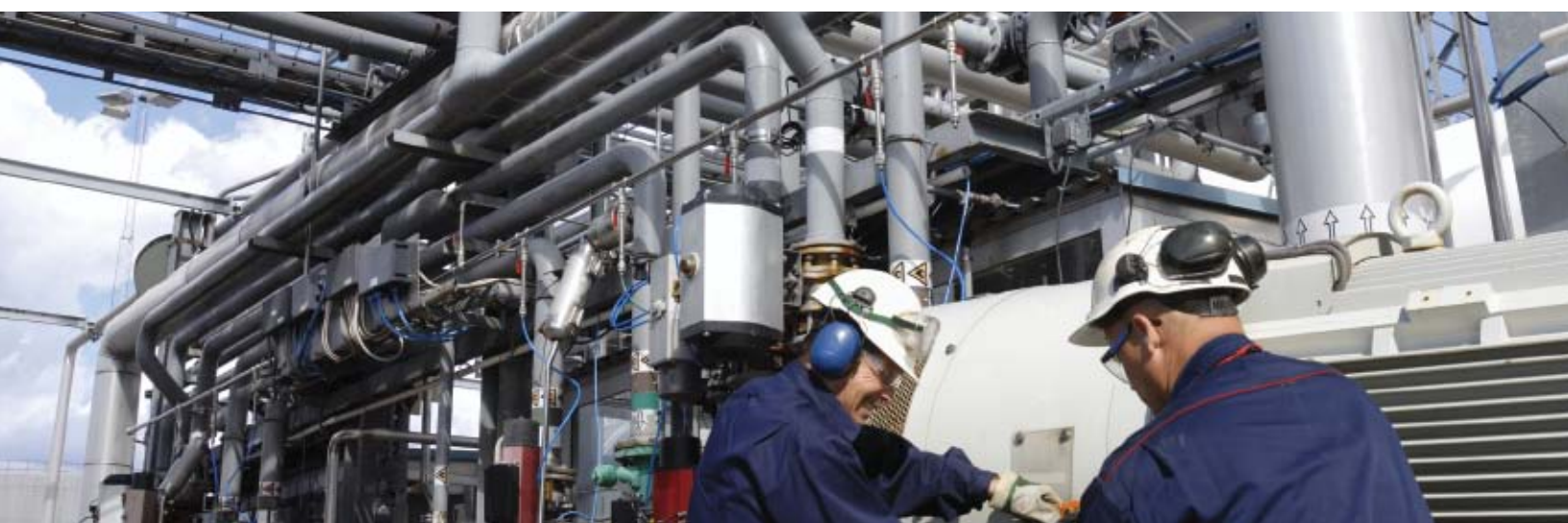

TRADEMARK INFORMATION

TOM WHEATLEY™ is a registered trademark which is owned by Cameron.

This document contains references to registered trademarks or product designations, which are not owned by Cameron.

Trademark	Owner
INCONEL	INCO NICKEL SALES, INC.
STELLITE	DELORO STELLITE COMPANY, INC.
TEFLON	E.I. DUPONT DE NEMOURS & COMPANY
VITON	E.I. DUPONT DE NEMOURS & COMPANY

**VALVES & MEASUREMENT**

3250 Briarpark Drive, Suite 300
Houston, TX 77042
USA Toll 800 323 9160

For the most current contact and location information go to: www.c-a-m.com